

CV#	Function/Default Value	CV#	Function/Default Value		
73	Route 6 Cell 5	00	86	Route 7 Cell 8	00
74	Route 6 Cell 6	00	87	Route 8 Switch State	00
75	Route 6 Cell 7	00	88	Route 8 Cell Address Adder	00
76	Route 6 Cell 8	00	89	Route 8 Cell 1	00
77	Route 7 Switch State	00	90	Route 8 Cell 2	00
78	Route 7 Cell Address Adder	00	91	Route 8 Cell 3	00
79	Route 7 Cell 1	00	92	Route 8 Cell 4	00
80	Route 7 Cell 2	00	93	Route 8 Cell 5	00
81	Route 7 Cell 3	00	94	Route 8 Cell 6	00
82	Route 7 Cell 4	00	95	Route 8 Cell 7	00
83	Route 7 Cell 5	00	96	Route 8 Cell 8	00
84	Route 7 Cell 6	00	97	Ops Mode Address	00
85	Route 7 Cell 7	00	98	Ops Mode Address Adder	00

# SRC8 Switch & Route Controller

- > Controls eight switches
- > Drives eight pair of switch status LEDs
- > Drives eight low current switch machines
- > Eight configurable routes
- > Switch position reporting
- > Featuring “Smart” Programming
- > Communication via LocoNet®

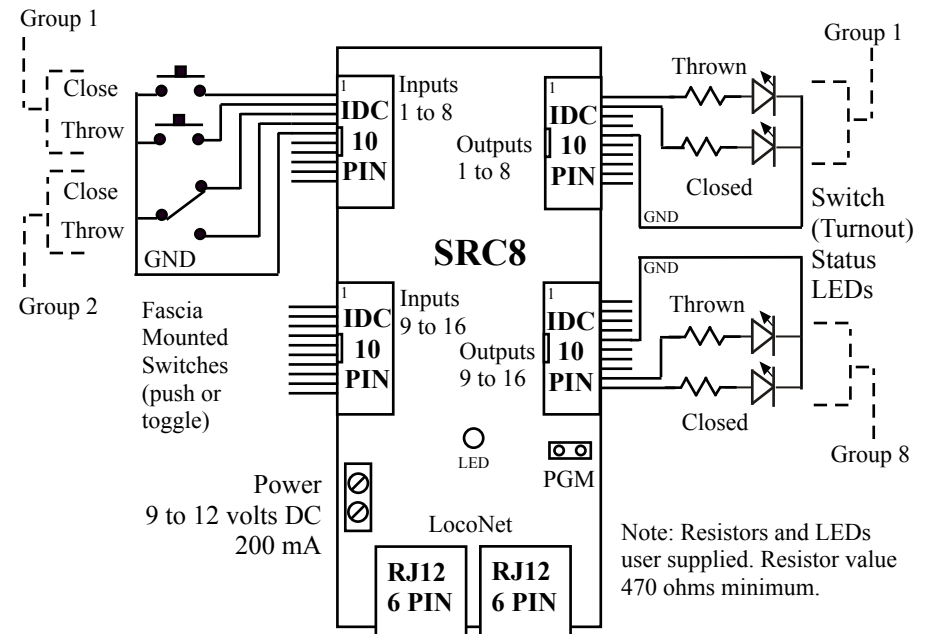

**WARNING:** This product contains a chemical known to the state of California to cause cancer, birth defects or other reproductive harm.



## 1 Operation

The SRC8 can control eight switches (turnouts) and display the state (closed or thrown) of those eight switches. To accomplish this task, the SRC8 has two inputs and two outputs for each switch. This is called a group. Thus, there are eight switch groups each with their own address. Activating a group input (close or throw) sends a switch command, using the group's address, over LocoNet just like throttles do. The SRC8 monitors LocoNet for switch commands from all sources, including those from itself. When the SRC8 receives a switch command with an address that matches a group's address, the status of the switch state (closed or thrown) is displayed via LEDs. The switch group address is determined by the SRC8 base address or by an individual alternate group address. When an alternate group address is assigned, it replaces that group's base address.

The SRC8 supports eight routes. Each route has eight cells. Each cell holds a switch address that is completely independent of a switch group address. The group addresses are for switch control and status display only. When a route is executed, switch commands are sent for each cell containing an address. A route is executed when a switch command from any source, including those from the SRC8, matches the address and switch state in the first cell of any route. The first route cell does not have to contain a switch address that is the same as one of the switch group addresses. The SRC8 would not be able to execute that route, but devices such as throttles, computers, and other SRC8s can. Optionally, a route can be executed by a block sensor message. One could automatically align several switches went a block became occupied.

Sometimes it's desirable to control all of the switches contained in a route individually, without executing the route. This can be achieved with Pseudo switch addresses. A Pseudo address is any address that does not match the address of any switch on the layout. For example, some people start the addressing of their real switches at 101, so they can use 1 through 99 for their routes. Lets say you want to control a yard ladder that contains switch addresses 101, 102, 103 and 104. By programming the first route cell with the address "1", "1" becomes the address that executes that route. Since there are no switches on the layout with the address of "1", no switch will operate when the command for address "1" is actually sent by the system, but the rest of the route will execute as intended. Because switch address 101 is in the second route cell for that route, you can control switch address 101 by itself without affecting any other switch.

A route can execute other routes (nested). This occurs when a route cell has an address that matches the address in the first cell of another route.

**Warning:** Do not create recursive loops. That is, do not have a route executing itself or two routes executing each other. Otherwise various unexplained problems will occur.

The SRC8 can be used to report switch position. Any of the groups can be used to initiate a feedback message that tells the system the actual state (closed or thrown) of the switch. Typically microswitches are mechanically linked to the switch. When the switch moves a microswitch is activated, grounding a SRC8 input. As an option, the status display LEDs will show the switch state based on switch feedback messages in addition to the regular switch command messages.

## 6 Summary of Configuration Variables

CV#	Function/Default Value	CV#	Function/Default Value
1	Base Address	01	37 Route 3 Switch State
2	Configuration	00	38 Route 3 Cell Address Adder
3	Manufacturer Version No.	-	39 Route 3 Cell 1
4	Manufacturer ID	-	40 Route 3 Cell 2
5	Send Delay	00	41 Route 3 Cell 3
6	Switch Postion Report	00	42 Route 3 Cell 4
7	Sensor Route Execution	00	43 Route 3 Cell 5
8	Alt Address Adder	00	44 Route 3 Cell 6
9	Group 1 Alt Address	00	45 Route 3 Cell 7
10	Group 2 Alt Address	00	46 Route 3 Cell 8
11	Group 3 Alt Address	00	47 Route 4 Switch State
12	Group 4 Alt Address	00	48 Route 4 Cell Address Adder
13	Group 5 Alt Address	00	49 Route 4 Cell 1
14	Group 6 Alt Address	00	50 Route 4 Cell 2
15	Group 7 Alt Address	00	51 Route 4 Cell 3
16	Group 8 Alt Address	00	52 Route 4 Cell 4
17	Route 1 Switch State	00	53 Route 4 Cell 5
18	Route 1 Cell Address Adder	00	54 Route 4 Cell 6
19	Route 1 Cell 1	00	55 Route 4 Cell 7
20	Route 1 Cell 2	00	56 Route 4 Cell 8
21	Route 1 Cell 3	00	57 Route 5 Switch State
22	Route 1 Cell 4	00	58 Route 5 Cell Address Adder
23	Route 1 Cell 5	00	59 Route 5 Cell 1
24	Route 1 Cell 6	00	60 Route 5 Cell 2
25	Route 1 Cell 7	00	61 Route 5 Cell 3
26	Route 1 Cell 8	00	62 Route 5 Cell 4
27	Route 2 Switch State	00	63 Route 5 Cell 5
28	Route 2 Cell Address Adder	00	64 Route 5 Cell 6
29	Route 2 Cell 1	00	65 Route 5 Cell 7
30	Route 2 Cell 2	00	66 Route 5 Cell 8
31	Route 2 Cell 3	00	67 Route 6 Switch State
32	Route 2 Cell 4	00	68 Route 6 Cell Address Adder
33	Route 2 Cell 5	00	69 Route 6 Cell 1
34	Route 2 Cell 6	00	70 Route 6 Cell 2
35	Route 2 Cell 7	00	71 Route 6 Cell 3
36	Route 2 Cell 8	00	72 Route 6 Cell 4

## 5 Switch Machine Drive

The SRC8 is capable of driving low current stall type switch machines. It has been tested with the Tortoise TM switch machine and can drive up to eight of them. Programming is the same whether using a switch machine or LEDs.

Each switch machine is connected to one of the SRC8 group outputs. One of the motor terminals is connected to the closed (green LED) output and the other motor terminal is connected to the thrown (red LED) output. When the SRC8 receives a switch command for that group, lets say a close command, 5 volts is applied to the closed output. The thrown output is at ground, so 5 volts is applied to the motor. It then moves in the close direction. Likewise, when a throw command is received for that group, 5 volts is applied to the thrown output. The closed output is now at ground, so 5 volts is applied to the motor in the opposite direction. Consequently, it moves in the throw direction.

Since the SRC8 uses 5 volts for motor drive, the switch machine moves slower than if 12 volts were applied.

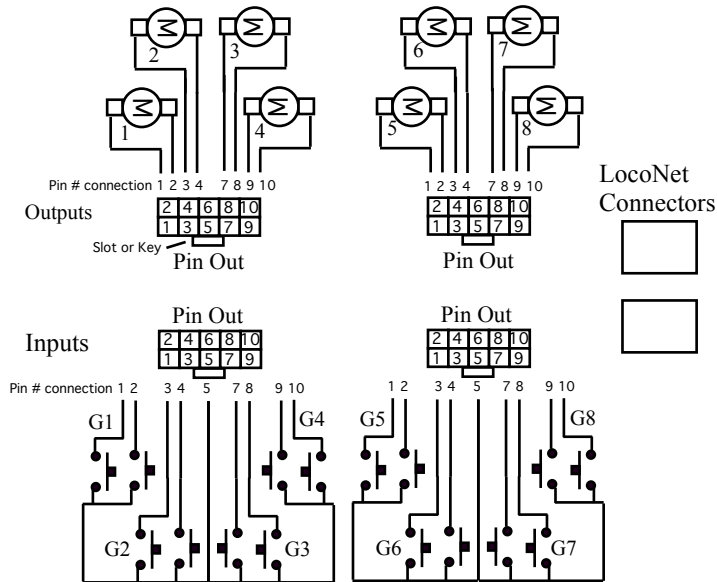

SRC8 wiring for push buttons and stall type motors

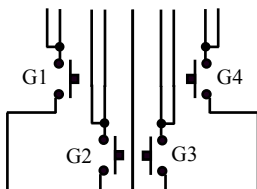

Optional wiring for push buttons for toggle feature

An input initiates the sending of a message when it is grounded. If both group inputs are grounded at the same time, the group outputs will switch states or toggle. A single button can then be used to toggle a switch.

As an option, group 1 inputs can send system commands.

The SRC8 is pre-programmed to operate with switch numbers 1 to 8 and is ready to use. At power on all status LEDs will be lit for about four seconds as a lamp check.

## 2 Configuration Variables (CVs)

The SRC8 supports **Paged Mode in Service Mode Programming** and **Operations Mode Programming**. To program in Paged mode, first connect the programming terminal (PGM) pins together (the supplied shorting bar can be used) with power off. Then connect power from a DC power supply. Each time a CV is programmed successfully, the LED will flash. Also, if any status LEDs are connected, they will flash. To enter normal operation, remove power and then the connection between the programming (PGM) pins and connect to the DC power supply. Even though the Paged Service Mode is used for programming the SRC8, the programming track is not used. The SRC8 intercepts the throttle's LocoNet messages to the command station to execute the programming commands. This means there won't be an actual decoder on the programming track and some systems may give a "nothing on track" error. That is OK.

To program in Ops mode, the ops address must be set and Configuration Option 5 must be enabled. Ops mode programming allows you to program route cells without using the programming terminal pins and turning power off and on.

Programming CV3 with 170 will "reset" all CVs from 5 and above to the default value. To disable a route no longer in use, program the route cell 1 address and route cell address adder with zero.

Some CVs require a calculation to determine their value because they contain information relating to several other CVs. To avoid these calculations use "Smart" programming. Also, the LN Programming Tool is available for download at Team Digital's web site.

### 2.1 SRC8 Address

This CV determines the base address. This is a switch (turnout) type address. A close or throw switch command is sent with an address as a function of this value when an input is activated. If a switch command is received with an address in this range, the respective switch status LED is lit. The SRC8 is pre-programmed with CV1 set to 1.

CV1 - Base address, value 1 to 127

Example: CV1 = 2, the group 1 address is 9, the group 2 address is 10, etc.

To calculate the value of CV1, use one of the following equations.

$CV1 = (Address + 7) \div 8$ , note that CV1 must be a whole number.

$Address = (CV1 \times 8) - 7$

Address Assignment Exar								
Group	1	2	3	4	5	6	7	8
CV1 = 1	1	2	2	4	5	6	7	8
CV1 = 2	9	10	11	12	13	14	15	16
CV1 = 6	41	42	43	44	45	46	47	48
CV1 = 127	1009	1010	1011	1012	1013	1014	1015	1016

## 2.2 Configuration

This CV determines the configuration which consists of several options.

CV2 - Configuration, value 0 to 57 Note: Some values are not valid. See below.

Option 1 - Memory. The SRC8 will remember the display switch status at power off and at power on will show the same status.

**Important:** In order for the status to be remembered, a 30 second delay is required from the last switch status change until power off .

Option 2 - System control. Activating the throw input of group 1 will send a Loco emergency STOP, activating the close input of group 1 will send a RESUME Loco operation.

Option 3 - System control. Activating the throw input of group 1 will turn OFF track power, activating the close input of group 1 will turn ON track power.

**Note:** Option 2 and 3 change the function of group 1 inputs from switch control to system control and are mutually exclusive. These options disabled the toggle feature for group 1. The function of group 1 outputs is unchanged.

Option 4 - Switch Position Feedback. The LEDs will show the switch state based on switch feedback messages in addition to the regular switch command messages.

Option 5 - Ops Mode Programming. Allows Operations mode programming to be performed.

Option 6 - Send Memory Output State. At power on, the switch status saved at power off will be sent out on Loconet. If any of the groups are set for switch position feedback then switch position feedback messages are sent for those groups. Option 1 must be enabled.

**Note:** Option 2 and 3 do not work with this option.

Configuration CV	Value	Select
No options	0	
Option 1 - Memory enabled	1	
Option 2 - Loco STOP/RESUME enabled	2	
Option 3 - Track power OFF/ON enabled	4	
Option 4 - Display switch feedback status enabled	8	
Option 5 - Ops mode programming enabled	16	
Option 6 - Send memory output state	32	
<b>CV value</b>		

To combine any of the options, add their values together. Options 2 and 3 can not be enabled at the same time.

Example: Enable options 1, 2 and 4

To calculate the value of CV2, add up the values.  $CV2 = 1 + 2 + 8 = 11$

## 4 “Smart” Programming

“Smart” Programming is a term used to describe a method to program CVs with the actual address instead of requiring a calculation to determine the CV value. Consequently, the programming task become much easier. In “Smart” Programming you use the throttle just like you normally would to select and send switch commands. Also, you use the push buttons and LEDs that are normally connected to the SRC8. The push buttons are used to select alternate group addresses or route cells for programming, while the LEDs are used to indicate the status of the programming. When you send a switch command with the throttle, the CV is programmed. You don’t need to be concerned about switch state CVs or address adder CVs. You don’t even need to know the CV number. “Smart” Programming takes care of all of that. Send another switch command and the next address is programmed. There is no need to go into the Page Service Mode to program each CV. However, there are some limitations. “Smart” Programming can not be used to program CVs 1, 2, 5 or 6. It also requires momentary push buttons be connected to the SRC8’s inputs and LEDs with appropriate resistors connected to the SRC8’s outputs. The maximum address is 511.

The inputs and outputs of the SRC8 are numbered 1 to 16. See section 3.4 for the relationship between the connector pin number, the group numbers and the input and output numbers.

To use “Smart” Programming:

1. With power off, connect the programming terminal (PGM) pins together.

2. Apply power.

3. To begin programming the alternate group addresses, press both push buttons 1 and 2 at the same time so that LED 1 and 2 are both lit.

Or

To begin programming the cells in a route, press one of the first eight push buttons so that the corresponding LED is lit. The first eight buttons correspond to the eight routes.

4. Use the throttle to select the first switch address to be programmed. Send the switch command by selecting the status (close or throw). LED number 9 will light. This indicates the first alternate group address or route cell is programmed. LEDs 9 to 16 indicate which of the eight group addresses or route cells have been programmed. The next switch command you send programs the next address and the next LED is lit. Repeat step 4 until you have programmed the desired number of addresses. If you accidentally send the wrong switch command, press push button 16 to go back to the previous position.

Go to step 3 to start programming another route.

**Note:** Even though an alternate group address does not have a CV for its status (close or throw) you still have to send the switch command with close or throw. When programming alternate group address, you can skip a group by pressing push button 9.

5. To stop programming, remove power and disconnect the programming terminal (PGM) pins.

### 3 Connections

#### 3.1 Power

The power connector is non polarized. Either terminal can be connected to plus or minus. The power supply should provide 9 to 12 volts DC with at least 200ma of current.

#### 3.2 Input Interface

The normal or default state of each input is at 5 volts when no device is connect. This is a hi or true state. When the input is connected to ground by a push button switch or block sensor the state is low or false. A voltage higher than 5 volts must not be applied to an input.

#### 3.3 Output Drive

The output supplies about 5 volts to drive LEDs and other low current devices such as low current stall type switch machines. The SRC8 has been tested with a Tortoise™ switch machine which can be used for a switch machine drive.

#### 3.4 10 PIN Input and Output

Input and output connectors are flat ribbon cable Insulation Displacement (IDC) type. They have the same pin definitions. Jameco #32491 will work as the mating connector. See the diagram on the front page for connector location.

**Warning:** Do not connect the power supply ground (minus) to the ground (minus) pin of the 10 pin IDC connector. Do not connect any outputs together or to other SRC8 outputs.

Conn	-----	Outputs 1 to 8	-----	-----	Outputs 9 to 16	-----				
Pin #	1	2	3	4	5	6	7	8	9	10
Output#	1	2	3	4	-	+	5	6	7	8
Group#	1t	1c	2t	2c	-	+	3t	3c	4t	4c

1	2	3	4	5	6	7	8	9	10
9	10	11	12	-	+	13	14	15	16
5t	5c	6t	6c	-	+	7t	7c	8t	8c

Conn	-----	Inputs 1 to 8	-----	-----	Inputs 9 to 16	-----				
Pin #	1	2	3	4	5	6	7	8	9	10
Input#	1	2	3	4	-	+	5	6	7	8
Group#	1t	1c	2t	2c	-	+	3t	3c	4t	4c

1	2	3	4	5	6	7	8	9	10
9	10	11	12	-	+	13	14	15	16
5t	5c	6t	6c	-	+	7t	7c	8t	8c

Top view of connectors

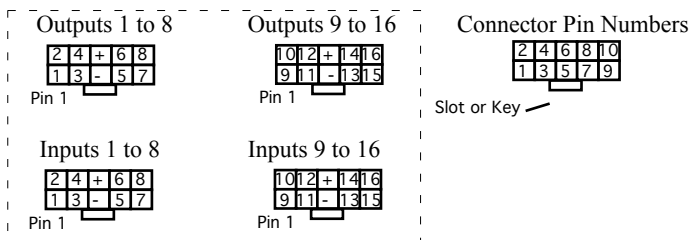

#### 2.3 Send Address Delay

This CV determines the time delay the SRC8 waits before sending the next address in a route. Some switch machine drivers require a time delay between switch activation. CV5 - Send address time delay, value 0 to 255. The delay is the CV5 value x 0.25 seconds.

Delay between sending route addresses								
CV5 Value	0	1	2	4	8	12	16	20
Delay (sec)	0	0.25	0.5	1	2	3	4	5

#### 2.4 Alternate Group Address

These CVs determine the optional alternate group address. It replaces the base address for that group and works the same way. A non-zero value will cause the alternate address to be used instead of the base address.

CV9, 10, 11, 12, 13, 14, 15, 16 - Alternate Group Address, value 0 to 255

The alternate group address can be increased to a maximum of 511 by using the address adder of 256. If the address adder is used, these CVs can then have a value of zero.

#### 2.5 Alternate Group Address Adder

This CVs determine if 256 is added to the alternate address.

CV8 - Alternate Group Address Adder, value 0 to 255

Example: 256 is added to the alternate address for group 1, CV9 and group 7, CV15.

To calculate the value of CV8, add up the individual group values. CV8 = 1 + 64 = 65

Alternate Group Address Adder Example								
Group	1	2	3	4	5	6	7	8
Group Value	1	2	4	8	16	32	64	128
Add 256	x						x	
CV8 = 65	1	0	0	0	0	0	64	0

#### 2.6 Route Switch State

These CVs determine the switch state (close or throw), of the switch address in the route cell. Each cell has a close and throw value. A close always has a zero ("0") value. Even if an address is not used, a close or throw value must be assigned.

CV17, 27, 37, 47, 57, 67, 77, 87- Route switch state value, 0 to 255

Example: For route 1, close switches 2, 4, 7 and 8, and throw switches 1, 3, 5 and 6.

To calculate the value of CV17, add up the individual cell values. CV17 = 1+4+16+32 = 53

Switch State Example for Route 1								
Route Cell	1	2	3	4	5	6	7	8
Cell Value	1	2	4	8	16	32	64	128
Assigned State	t	c	t	c	t	t	c	c
CV17 = 53	1	0	4	0	16	32	0	0

t = throw  
c = close

## 2.7 Route Cell

These CVs hold the address included in the route. The first cell in the route holds the address of that route or lead address. If that value is zero that route is not defined. The route consists of up to eight addresses or to the first cell zero value.

- CV19 to 26 - Route 1 Cells, value 0 to 255
- CV29 to 36 - Route 2 Cells, value 0 to 255
- CV39 to 46 - Route 3 Cells, value 0 to 255
- CV49 to 56 - Route 4 Cells, value 0 to 255
- CV59 to 66 - Route 5 Cells, value 0 to 255
- CV69 to 76 - Route 6 Cells, value 0 to 255
- CV79 to 86 - Route 7 Cells, value 0 to 255
- CV89 to 96 - Route 8 Cells, value 0 to 255

The address in a cell can be increased to a maximum of 511 by using the route address adder of 256 as defined in section 2.8. If the address adder is used, these CVs can then have a value of zero.

Example of using SRC8 Routes

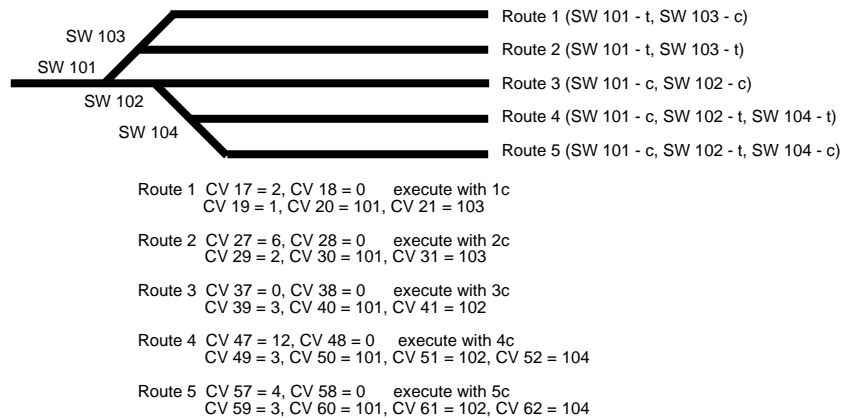

## 2.8 Route Address Adder

These CVs determine if 256 is added to the address in the route cell.

CV18, 28, 38, 48, 58, 68, 78, 88 - Route Cell Address Adder, value 0 to 255

Example: 256 is added to the address in cells 1, 2 and 6 of route 1.

To calculate the value of CV18, add up the individual cell values.  $CV18 = 1 + 2 + 32 = 35$

Address Adder Example for Route 1									
Route Cell	1	2	3	4	5	6	7	8	
Cell Value	1	2	4	8	16	32	64	128	
Add 256	x	x				x			
CV18 = 35	1	2	0	0	0	32	0	0	

## 2.9 Switch Position Report (Feedback)

This CV determines if activating a group input will send a switch position message. This is used to report the actual state of the switch (closed or thrown) instead of commanding a switch state. The address of the group and the function of the group output is unchanged.

CV6 - Switch Position Report, value 0 to 255

Example: Groups 1, 2, 3 and 4 report switch position.

To calculate the value of CV6, add up the individual group values.  $CV6 = 1 + 2 + 4 + 8 = 15$

Switch Position Report Example								
Group	1	2	3	4	5	6	7	8
Group Value	1	2	4	8	16	32	64	128
Report	x	x	x	x				
CV6 = 15	1	2	4	8	0	0	0	0

## 2.10 Sensor Route Execution

This CV determines if a route will be executed by a sensor type message instead of a switch message. One application might be to activate a switch(es) when a block becomes occupied. In the Route Switch State use a 'c' for occupied and a 't' for unoccupied when using a sensor message to execute a route.

CV7 - Sensor Route Execution, value 0 to 255

Example: Routes 7 and 8 executed with a sensor message.

To calculate the value of CV7, add up the individual group values.  $CV7 = 64 + 128 = 192$

Sensor Route Execution Example								
Route Cell	1	2	3	4	5	6	7	8
Cell Value	1	2	4	8	16	32	64	128
Execute							x	x
CV7 = 192	0	0	0	0	0	0	64	128

## 2.11 Operations Mode Address

These CVs determine the ops mode address. This is a loco address and therefore must be unique among locomotives addresses.

CV97 - Address, value 1 to 255 CV98 - Address adder, value 0 to 7

Address = value of CV1 + address adder

If an address greater than 255 is needed then use the address adder. The following table shows the CV value to use for the adder.

Example: Address of 101, set CV97 = 101 & CV98 = 0

Address of 901, set CV97 = 133 & CV98 = 3

Address Adder									
CV value	0	1	2	3	4	5	6	7	8
Add	0	256	512	768	1024	1280	1536	1792	2048
									2304